



This manual is for reference and historical purposes, all rights reserved.

This page is copyright© by M. Butkus, NJ.

This page may not be sold or distributed without the expressed permission of the producer
I have no connection with any camera company

On-line camera manual library

This is the full text and images from the manual. This may take 3 full minutes for the PDF file to download.

If you find this manual useful, how about a donation of \$3 to: M. Butkus, 29 Lake Ave., High Bridge, NJ 08829-1701 and send your e-mail address so I can thank you. Most other places would charge you \$7.50 for a electronic copy or \$18.00 for a hard to read Xerox copy.

This will allow me to continue to buy new manuals and pay their shipping costs.

It'll make you feel better, won't it?

**If you use Pay Pal or wish to use your credit card,
click on the secure site on my main page.**



Rolleicord
V

IN PRACTICAL USE

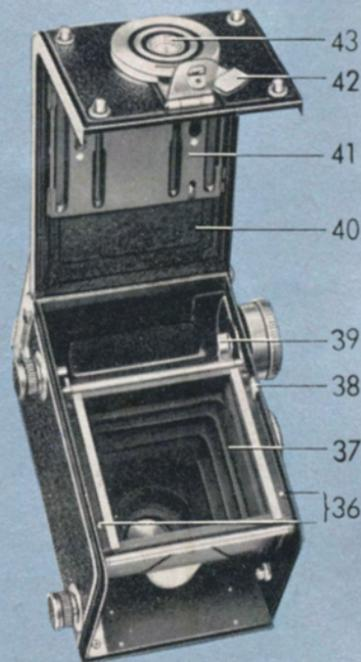
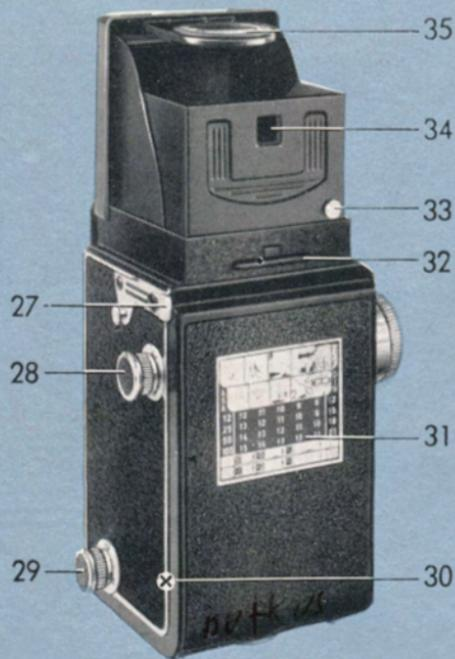
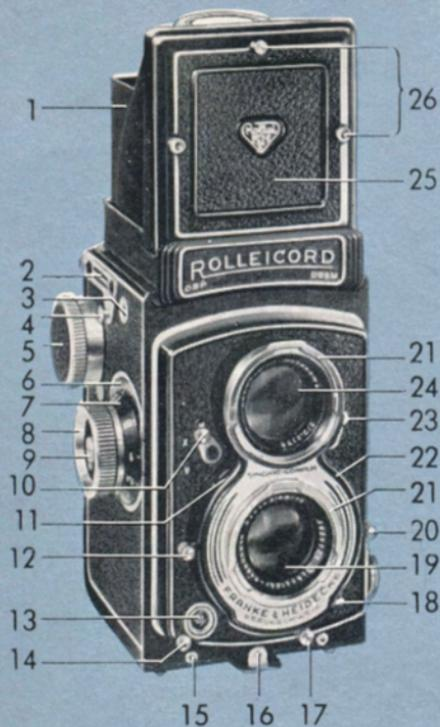

- 1 Focusing hood
- 2 Eyelet slot for neck strap
- 3 Exposure counter window
- 4 Strap hook
- 5 Film winding knob

- 6 Depth of field scale
- 7 Focusing scale
- 8 Focusing knob
- 9 Adjustable film speed reminder

- 10 Synchro lever (also serves as cocking lever for self-timer)
- 11 Indicator window for shutter speeds

- 12 Shutter speed control lever
- 13 Flash cable socket
- 14 Locking device for flash cord plug

- | | |
|--|---|
| 15 Locating sockets for
Panorama Head | 30 Focal or film plane
(focusing distances
measured from this line) |
| 16 Back lock clip | 31 Exposure table |
| 17 Shutter tensioning
and release lever | 32 Retaining device for
Rolleigrid or Rolleikin
ground glass mask |
| 18 Cable release socket | 33 Release button for
direct view finder flap |
| 19 Taking lens | 34 Rear sight for direct
view finder |
| 20 Diaphragm control
lever | 35 Focusing magnifier |
| 21 Double bayonet mount
for lens accessories
and lens hood | 36 Indicator marks for
starting No. 120 roll
film |
| 22 Indicator window
for diaphragm and
light value scale | 37 Anti-reflection baffles |
| 23 Double exposure preven-
tion lever and release | 38 Sliding lever
for engaging counter |
| 24 Viewing lens | 39 Winding key
of take-up spool |
| 25 Direct view finder flap | 40 Combination back
for 120 (B II 8) and
35 mm. film |
| 26 Pin-socket for
Rolleikin direct view
finder mask | 41 Adjustable film
pressure plate |
| 27 Back hinge
with safety lock | 42 Back locking lever |
| 28 Take-up spool knob | 43 Tripod socket |
| 29 Film spool knob
(and Rolleikin-rewind
knob) | |

The Rolleicord V is equipped with the high quality Schneider Xenar $f:3.5$ lens and many features of important technical advantage. Precise construction of the camera, fool-proof operation, all controls easily manipulated in picture-taking position: These are the features which, together, make up the convenient operating method of the Rollei. The fine photographic performance of this camera is made fully available through its extremely simple operation.

The following pages will describe in detail the principle as well as the correct methods of handling the camera. Many rules and hints are included, making it possible for even the inexperienced to acquire soon proficiency in the practice of Rollei photography.

We trust that this booklet will be a helpful and constant guide to the new Rolleicord owner, speeding him on his way to real success with the camera.

FRANKE & HEIDECHE
BRAUNSCHWEIG

THE QUICK BASIC PRINCIPLE

After the exposure:
advance film

Flash exposures:
adjust M-X lever

Self-timer pictures:
cock mechanism

Check exposure number

Observe depth of field

FOCUS

Shutter speed {
read
adjust

Flash pictures:
connect flash gun,
unlock flash cord plug
before pulling it out

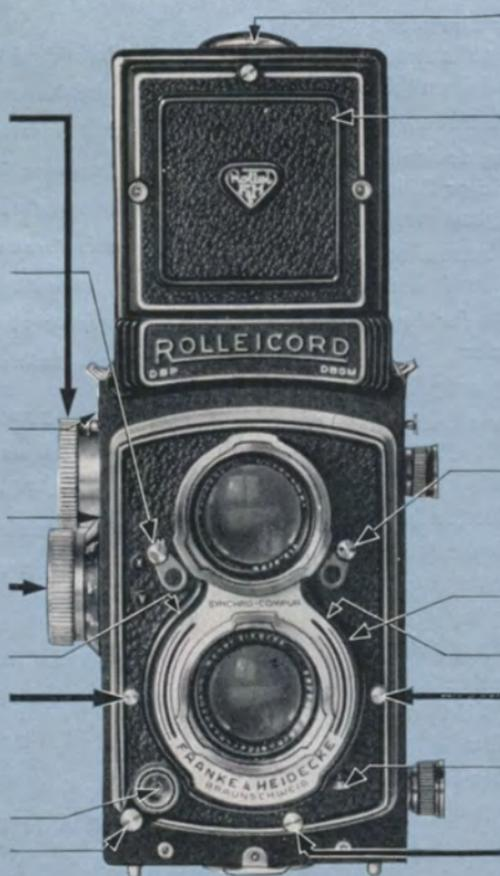

Check focus and composition

Sports pictures:
use direct view finder

For intentional double
or multiple exposures or when
using Rolleikin 2 or plate back:
release double exposure
prevention lock

Read light value

Read }
Adjust } diaphragm opening

Screw in cable release
(when required)

Tension and release shutter

REFERENCE INDEX:

Page:

- 6 **I. A Brief Rolleicord-Anatomy**
- 12 **II. Rolleicord in Operation**
- 12 Ever Ready Case
- 12 Lens Cap
- 14 Holding the Camera
- 16 Focusing Hood
- 16 Focusing Magnifier
- 17 Direct View Finder
- 18 Focusing
- 18 Diaphragm
- 19 Depth of Field
- 24 Shutter Speed
- 24 Light Value
- 24 Double Exposure Prevention
- 25 Tensioning and Releasing
- 26 Exposure and Light Value
- 27 Film Speed Reminder
- 30 Self Timer

Page:

- 31 **III. Flashlight Technique**
- 36 **IV. Loading and Film Transport**
- 36 Back
- 38 Inserting Film Spool
- 40 Starting of Film
- 41 Film Transport
- 42 **V. Tips on Picture-Taking**
- 42 Landscapes
- 44 Portraits
- 45 Children
- 45 Animals
- 46 Snapshots
- 47 Sports
- 48 Theatre and Music Hall
- 48 Night Photography
- 49 Copying
- 50 Reflecting Surfaces

Page:

- 51 Plants
- 51 Color Pictures
- 52 Micro Photography
- 52 Care of Camera
- 52 In Case of Damage to the Camera

Tables:

- 21 Depth of Field
- 23 Speed of Moving Objects and Shutter Speed
- 28 Exposure
- 29 Speed of Emulsions
- 32 Flash-Contact and Shutter Speed
- 53 Practical Accessories
- 54 Rollei Filters
- 55 Rolleinars

Important: Before attempting to use or handle the camera we urge you to carefully read pages 12, 16, 24 and 36.



I. A BRIEF ROLLEICORD-ANATOMY

The Rolleicord owes its photographic efficiency to the classic Rollei design: the twin-lens reflex-principle.

It adopted this basic idea from the several years older model, the Rolleiflex. To achieve the highest possible performance in its price field, the Rolleicord went its own way in the matter of mechanical development. This resulted in certain differences between the two cameras. In spite of these variations numerous common advantages exist in operation and practical use, so that working rules conform in many respects.

Construction of the Twin Lens Reflex

In the Rolleicord two separate cameras are joined in a twin-camera with a common sturdy die-cast body: the bottom half is the

taking-camera, in which the film is exposed, and the upper half is the

viewing-camera, which is designed on the mirror-reflex principle. Its special task is to make the focusing visible on the ground glass and to supply a control

image essentially similar to that of the prospective picture.

The image forming rays are transmitted by the fully open viewing lens, projected on to the ground glass screen via the mirror and the result is a right-side-up ground glass image, in the full size of the original picture. This viewing image is visible at all times and every detail of composition and framing may be watched even during exposure.

The ground glass screen is ruled vertically and horizontally across the center making it possible to detect errors, such as lines which converge that should be parallel or a slanting horizon, in time to notice and correct them. It is easy to straighten or level the camera by means of the lines on the ground glass screen.

Above all, the ground glass screen provides the means for **focusing the camera**. This is accomplished by rotating the focusing knob. Both lenses, which are inflexibly coupled to each other by means of a sturdy common front plate, are thereby adjusted simultaneously: a sharp viewing image, therefore, guarantees an equally sharp picture. Since the Rolleicord is equipped with a fast viewing lens and an optically prepared ground glass screen, the viewing image is extremely

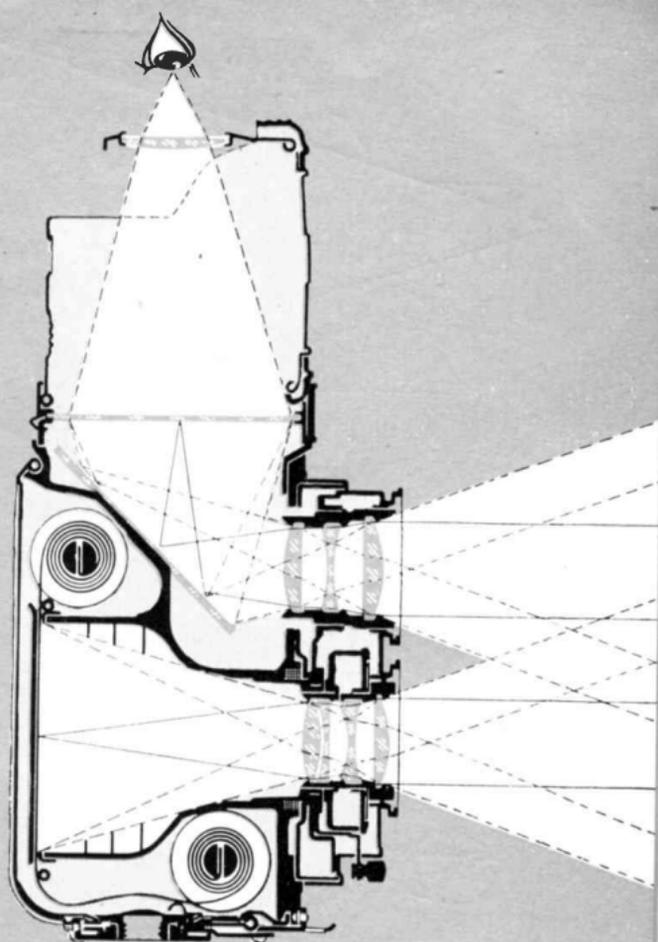

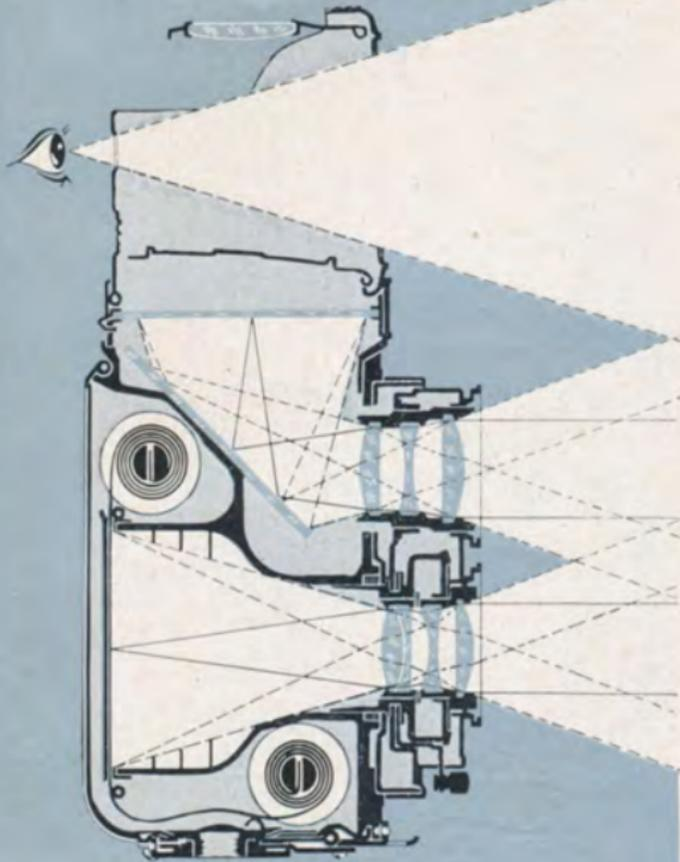

bright and clear and focusing can be done very critically.

The **focusing hood**, which is designed for one-hand operation, is kept in both open and closed positions by spring tension. It is equipped with a **magnifier** offering approximately 2.5 times magnification for critical focusing.

After focusing the camera, the front flap of the focusing hood may be folded back: the focusing hood is thereby converted to an open frame type **view finder**, through which it is possible to view the subject in natural size and to follow action easily.

Focusing the front lens panel throughout the range from ∞ (infinity) - $35\frac{1}{2}$ inches (distances measured from the focal or film plane to the subject) is accomplished by one full turn of the focusing knob. The special design of the focusing mechanism (a cam-drive based on the principle of the archimedic spiral) insures uniform movement of the lens panel in both directions without play or backlash.

Tied in with the movement of the lenses is a simple sliding mechanism, located beneath the ground glass, providing completely automatic **parallax compensation**. Consequently, the final picture is always framed exactly as originally viewed on the ground glass screen. Similarly complete control can be had even when using supple-

mentary Rolleinar lenses for close-up work merely by adding the Rolleipar.

Diaphragm openings and shutter speeds are set by means of control levers on both sides of the taking lens and are observed through two separate indicator windows. The selected values are read from above.

Light value scale and shutter speed-diaphragm coupling simplifies the pre-selection of shutter speed and diaphragm opening by permitting a quick change to the desired combination.

The **Synchro-Compur shutter** has a single tensioning and release lever with double exposure prevention. The shutter can therefore be tensioned and immediately afterwards released without changing position of the hands. Thus all diaphragm and shutter manipulations are accomplished with the camera in operating position.

Since the two lenses are of identical focal length ($f = 75 \text{ mm}$, picture angle [across diagonal], 56°) it follows that the images in both sections of the camera will always be critically focused on the same portion of the subject simultaneously. The Schneider Xenar $f : 3.5$ taking lens, is a four glass construction with two cemented elements (modified Taylor-type) and features outstanding correction for black and white- and color pictures, while the three-element viewing-lens $f : 3.2$ meets with the special requirements for best



ground glass focusing. Both lenses are treated with abrasion resistant coating. The bayonet receptacles circling the mounts are intended for attaching the lens hood and supplementary optical accessories, which in this way will be held in optically correct position and form a solid unit with the camera.

The removable **combination back** is attached to the camera by means of two hinges with locking device and at the bottom it contains the tripod socket and the safety back lock. Its adaptability for the two picture sizes $2\frac{1}{4} \times 2\frac{1}{4}$ " and 24×36 mm. is the result of the adjustable film pressure plate which can be set for No. 120 (B II 8)-film (with paper backing), or for 35 mm. film (without paper backing) when used in conjunction with the Rolleikin 2 attachment. In both cases a film channel is created with a width that corresponds to the thickness of the film being used. Thus the film can be properly held in the focal plane, and also can slide through without undue friction when advanced.

Film Transport and Double Exposure Prevention

The film transport mechanism (for roll film) is equipped with a **double exposure prevention device**. Shutter and film transport are thus locked alternately so that the correct order of the operating steps necessarily has to be: advance film, tension shutter, release shutter.

Turning the film winding knob until it stops (film lock) will advance the film one full frame and at the same time cause the next number to appear in the exposure counter window. Now the shutter can be tensioned. After release, the operation of the inter-lock is reversed so that the shutter is locked until the film has been properly advanced to the next frame. In this way double exposures or blanks are neatly avoided.

In special cases – when using the Rolleikin 2 or Plate Back – the double exposure prevention lock must be released or else the shutter would be permanently

locked. If engaged after the exposure, the lock will furthermore serve as an effective shutter release guard.

- Intentional double or multiple exposures (trick shots) on roll film are also possible through temporary release of the lock.

Proper starting of the film when loading the camera is easily accomplished. Immediately after inserting the film it is advanced as far as the arrow mark on the paper backing. Closing the back at this point depresses the sliding lever and engages the film measuring mechanism. The knob can now be turned only the correct amount to the stop. The number in the film counter window will automatically advance from 0 to 1, when the film is ready for the first exposure.

The last sign visible in the exposure counter window (after No. 12) is a center-dotted circle \odot to indicate that all the film has been exposed. Opening the back will cause the counter dial to return to No. 0.



II. THE ROLLEICORD IN OPERATION

The Ever Ready Case

deserves mention here since it is so often used with the camera.

The case may also be used with the Rolleikin 2 attachment merely by removing the leather insert to permit passage of the larger counter knob. In order to assure solid contact when working with a tripod, do not use the ever ready case.

To Open: lift the top by grasping the snap catch buttons at the rear and fold forward and down ①.

To Close: pull the top over the camera and push down to engage the snaps. (Simultaneous folding of the focusing hood is also possible with this movement.) Always return focusing knob to infinity position since the extended front may otherwise interfere with closing the case.

Removal of Camera from Case: pull up the clips on the side walls of the case ②, spread the case apart, lift the camera forward and out ③.

Inserting Camera into the Case: pull up the side clips, spread the case apart and lower the camera backwards into the case. Push the clips through the strap holders of the camera.

For Cameras with Rolleikin 2: straighten out the five metal tabs, which hold the leather insert on the inside of the case, with a knife ④ and then push out the now superfluous disc ⑤.

The Lens Cap

The lens cap of light-metal serves to protect the lenses when not using the camera for any length of time or when traveling. It is attached to the bayonet ring of the taking lens by means of a locking knob. The cap fits in front of the lenses only when the upper part which is marked Rollei covers the viewing lens.

To Remove Lens Cap: slide the locking knob in the middle of the cap upwards ⑥.

Attaching Lens Cap: slide locking knob upwards, place cap over the mounts, slide knob downwards.

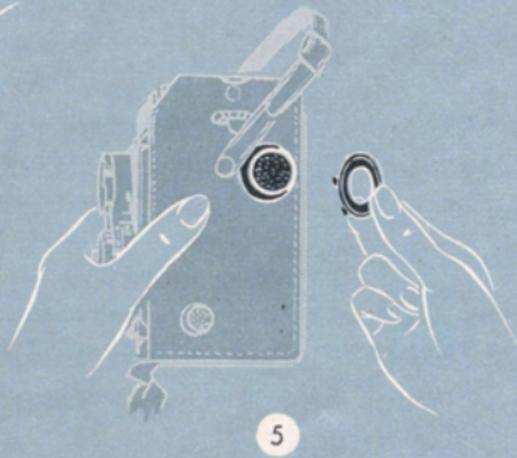
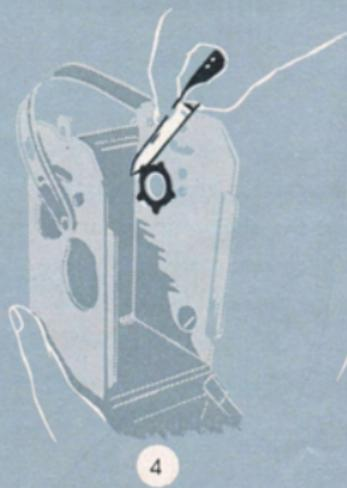
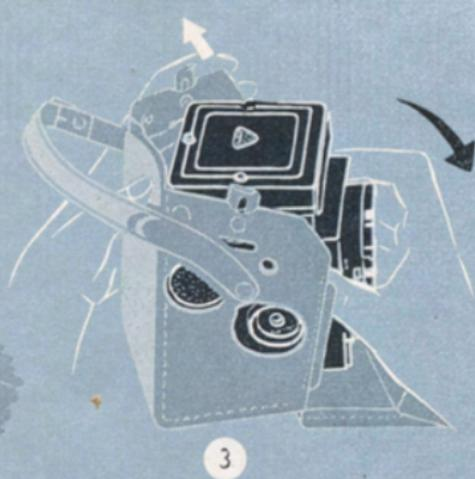
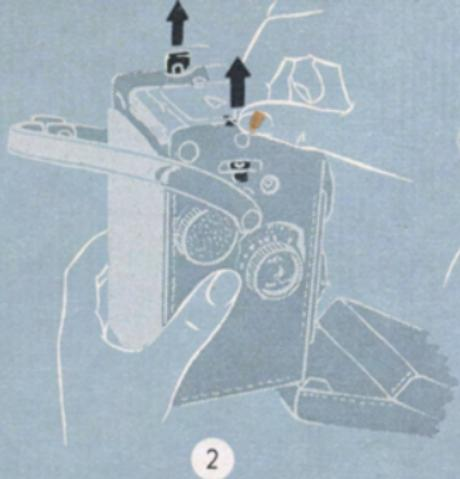



1



2



3



4

Holding the Camera

Basic rule: camera hanging around the neck with taut strap and held firmly with both hands. The left hand grasps the camera at the bottom, index finger on the combined shutter tensioning and release lever. The right hand takes over the focusing ①.

In this position shutter and diaphragm are easily controlled with two fingers.

The **carrying strap** is adjusted to a comfortable length, so that the camera may be carried on the shoulder when not in use. In order that the shutter may be released with taut strap to avoid camera movement, loop the strap around the left hand, thus shortening it to achieve normal viewing distance ②. Further shortening of the strap when using the magnifier can easily be effected by making use of the right hand in the same way ③.



5



6



7



8

Caution: a wrong or uncomfortable "grip" may cause you to inadvertently lift the hanging top of the ever ready case.

A **leather neck strap** is also available for working without the ever ready case. To attach: slip both ends through the strap holder slots and fasten to the strap hooks ④.

Waist-level or eye-level positions for the camera are considered normal for most pictures. The extremely flexible Rollei, however, readily permits exposures at or near floor level, overhead, shooting straight up or down, and occasionally, surprise snaps "around the corner". The illustrations ⑤-⑧ show a few possibilities for such pictures with the camera in different positions.



1



2



3

Focusing Hood

To open: lift the rear edge of the focusing hood cover - spring tension keeps it open ①.

To close: fold down focusing hood ②.

The focusing hood can also be folded down with the same hand movement that closes the ever ready case (see page 12).

The push-button at the rear of the focusing hood serves to hold the Rolleikin ground glass screen mask or the Rolleigrd lens.

Focusing Magnifier

To raise: push the direct view finder flap inwards - the magnifier springs into position ③.

To lower (before closing focusing hood): fold down magnifier ④.

Use of magnifier: use magnifier as close to the eye as possible.

The magnifier is interchangeable and may be replaced for the convenience of near or far sighted people. Strengths from minus 3 to plus 3 diopters are available.



4



5



6

Direct View Finder

To open: push the direct view finder flap inwards until it locks into place ④.

To Close: release the flap by means of the button on the back of the focusing hood - it will spring back into place ⑤.

The two pin-sockets and small knob on the front of the hood permit attachment of the Rolleikin direct view finder mask.

Changing Magnifier (if eye-sight demands)

To remove: take hold of magnifier by both surfaces, push it against the retaining spring (in direction of the hinge of the magnifier holder) and then fold it up and lift out.

To insert: place in socket and push back against spring until it can be snapped down into place.

Focusing

Focus the Rolleicord by turning the focusing knob, at the same time critically observing the sharpness of the ground glass screen image. The footage scale serves also to indicate the depth of field, a matter which need not concern you too much at first.

The magnifier facilitates the most critical focusing. Important:

Focus so that the greatest degree of sharpness prevails at main subject distance



The Diaphragm



The diaphragm controls the amount of light passing through the lens. It has a double effect:

Stopping down

increases the depth of field and
reduces the effective amount of light

Therefore, the exposure must be increased correspondingly at smaller diaphragm openings. The following table gives the ratio of exposure at the different openings:

Diaphragm	3.5	4	5.6	8	11	16	22
Exposure	$\frac{3}{4}$	1	2	4	8	16	32

Notice that each succeeding smaller stop requires exactly double the exposure of the preceding one. Only exception – the relation between f:3.5 and f:4 (see page 26).

The diaphragm scale itself is easily seen in the peep window to the left of the lens. The dot before f:3.5 indicates the position for f:4.

Setting of Diaphragm: by means of the diaphragm lever.

Depth of Field

Most picture subjects require that acceptable sharpness extend somewhat before and behind the exact distance focused on. Landscapes, for instance, require considerable "depth of field". Two factors influence the extent of the sharp zone: distance actually focused on and diaphragm opening.

In contrast to close-up focusing the sharp zone is many times greater when the lens is focused on long distance:

1. The depth of field increases with the taking distance

In any case, however, the sharp zone of the picture may be increased considerably by stopping down the diaphragm:

2. The depth of field increases when stopping down

As a practical rule the second alternative is preferable and only in emergency cases should the taking distance be increased because of loss in image size.

The extent of the depth of field at any distance may be read off on the focusing knob.

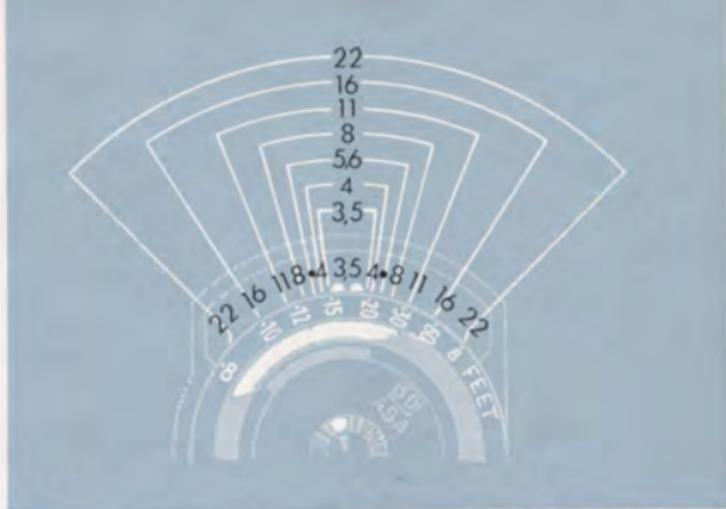

Depth of Field Scale

On and next to the focusing knob two scales are visible: the movable focusing scale with figures indicating feet and the non-movable diaphragm scale. Together, these comprise the depth of field indicator. The diaphragm values, which are arranged symmetrically in pairs on both sides of the central focusing point indicate the limits of the sharp focusing range at the various settings. The diaphragm opening at 3.5 is represented by the white center area and 5.6 by a dot.



1

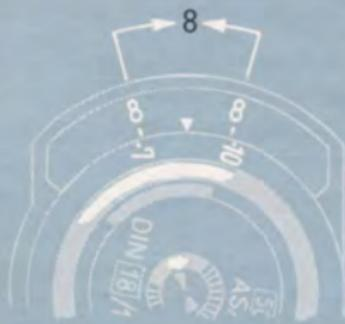

2

In Practice

After focusing, the near and far limits of the depth of field may be read off directly below the pair of figures indicating the diaphragm opening chosen.

Sharp focus extends throughout the area bracketed by the marks representing the selected diaphragm opening

1. Example: focusing to 15 ft with diaphragm opening 8 gives a depth of field from 10 ft to 30 ft approx., focusing to 10 ft with diaphragm opening f:22 gives on the other hand a depth of field from 8 ft to ∞ approx. (Stopping down improves the depth of field.)

Considerable stopping down necessitates greatly increased exposure time. To obtain depth of field with the largest possible diaphragm opening, a different method of focusing must be employed:

2. Example: the subject requires sharpness from 7 ft to 10 ft. (Other distances, if unknown, can be read directly off the scale after focusing separately to the limits required.) Procedure: the focusing knob is turned until both footage values are located opposite identical diaphragm openings, and in this way the most favourable diaphragm opening is obtained, in this case f:8.

Depth of Field Table (distances in feet)

Diaphragm		4	5.6	8	11	16	22	
Taking distance (in feet)	∞	141' - ∞	86' - ∞	61' - ∞	43' - ∞	31'4" - ∞	21'6" - ∞	15'7" - ∞
	60'	42' - 105'	35' - 198'	30'3" - ∞	25' - ∞	20'7" - ∞	15'10" - ∞	12'4" - ∞
	30'	24'9" - 38'	22'3" - 46'	20'2" - 59'	17'8" - 99'	15'4" - ∞	12'6" - ∞	10'3" - ∞
	20'	17'6" - 23'4"	16'3" - 26'	15'1" - 29'8"	13'8" - 37'	12'2" - 55'	10'4" - 290'	8'9" - ∞
	15'	13'7" - 16'10"	12'9" - 18'2"	12'1" - 19'10"	11'2" - 23'	10' - 29'8"	8'10" - 50'	7'8" - 350'
	12'	11'1" - 13'2"	10'6" - 13'11"	10' - 14'8"	9'5" - 16'8"	8'8" - 19'6"	7'8" - 27'1"	6'10" - 52'
	10'	9'4" - 10'10"	9' - 11'5"	8'7" - 12'1"	8'2" - 13'2"	7'7" - 14'10"	6'10" - 19'	6'1" - 27'5"
	8'	7'7" - 8'6"	7'5" - 8'10"	7'2" - 9'2"	6'10" - 9'9"	6'6" - 10'7"	6' - 12'5"	5'5" - 15'8"
	7'	6'8" - 7'4"	6'6" - 7'7"	6'5" - 7'10"	6'1" - 8'3"	5'9" - 8'10"	5'5" - 10'1"	4'12" - 12'1"
	6'	5'9" - 6'3"	5'8" - 6'5"	5'6" - 6'7"	5'4" - 6'11"	5'2" - 7'4"	4'9½" - 8'1"	4'5½" - 9'4"
	5'	4'10⅛" - 5'2"	4'9" - 5'3"	4'7⅞" - 5'5"	4'6⅜" - 5'7"	4'4½" - 5'10"	4'1⅝" - 6'4"	3'10⅜" - 7'1"
	4'	3'10⅜" - 4'1¼"	3'10⅛" - 4'2"	3'9⅜" - 4'2⅞"	3'8⅜" - 4'4¼"	3'7¼" - 4'6"	3'5⅜" - 4'9⅜"	3'3⅜" - 5'2"
	3.5'	3'5⅛" - 3'6⅞"	3'4⅝" - 3'7½"	3'4" - 3'8⅛"	3'3¼" - 3'9⅛"	3'2⅝" - 3'10½"	3'1" - 4'⅞"	2'11⅜" - 4'4⅛"
	3'	2'11⅜" - 3'⅝"	2'11" - 3'1"	2'10½" - 3'1½"	2'10" - 3'2¼"	2'9⅜" - 3'3⅛"	2'8¼" - 3'4¼"	2'7⅛" - 3'6⅞"
Diaphragm	3.5	5.6	8	11	16	22		

The Depth of Field Table

Since the sharp zone in the picture does not end abruptly, but gradually changes to something less sharp, it is generally sufficient to read the depth of field in round figures. With this in mind the scale on the focusing knob has been calibrated for quick and practical use.

If exact figures are desired, these may be found in the table on page 21.

For normal use the upper of the double row of diaphragm figures is used as in the case when an enlargement is to be made later from the entire $2\frac{1}{4} \times 2\frac{1}{4}$ negative. (These diaphragm openings are based on a circle of confusion of $1/1400$ of the focal length.)

On the other hand if enlargements are to be made from a small portion of the negative (or Rolleikin negatives), it is advisable to go by the lower row of diaphragm openings (circle of confusion = $f/2000$).

Explanation: the degree of sharpness required from a negative is exclusively dependent on the magnification of the prospective enlargement and its subsequent viewing distance.

In order to obtain a correct perspective impression at 10" (a comfortable viewing distance) a whole Rollei negative would have to be enlarged $3.3 \times$ to $7\frac{1}{2} \times 7\frac{1}{2}$ ". Enlargements of this size, viewed at 10", determine the basis for the minimum acceptable sharpness. With this in mind the size of the circle of confusion is computed and the limits of the depth of field ascertained. Negatives made in this way will permit enlargements also to larger sizes, while still retaining the same impression of sharpness. This is because the viewing distance is always correspondingly increased.

With enlargements from portions of Rollei negatives or from Rolleikin negatives, the requirements with regard to sharpness are more critical. In this case depth of field is calculated using a smaller circle of confusion. In practical use the required depth is obtained through the use of a smaller diaphragm opening. The effectiveness of the scale on the camera itself may be extended in the same manner merely by using the next smaller diaphragm opening than the one indicated for the desired zone.

If enlargements of very great size are to be made, use a diaphragm opening two stops smaller than the one indicated.

Speed of Moving Subjects and Shutter Speeds

		Miles per hour approximately																	
		3 mph		6 mph			12 mph		30 mph			60 mph		120 mph					
Example:		Pedestrians		Runners Moving air			Bicycles Windy		Light Athletics Stormy Surf			Automobiles Railway Trains Racing		Motor Racing					
Distance (yards)	40		1/30	1/60	1/30	1/60	1/125	1/60	1/125	1/250	1/125	1/250	1/500	1/250	1/500		1/500	50	Distance (yards)
	15	1/30	1/60	1/125	1/60	1/125	1/250	1/125	1/250	1/500	1/250	1/500		1/500				25	
	8	1/60	1/125	1/250	1/125	1/250	1/500	1/250	1/500		1/500							12	
	4	1/125	1/250	1/500	1/250	1/500		1/500										6	

Moving Objects require short shutter speeds in order to be reproduced sharply. For this purpose the table contains computed minimum values, depending on the factors: speed, distance and direction.

Taking distance: the yard column on the left stands for sufficient sharpness (f/1400), the yard column on the right for increased sharpness (f/2000). In spite of

these normally correct figures, it is often possible in actual photography to use longer shutter speeds. This is because the eye interprets slight unsharpness as giving an added impression of speed.

Long arrow = direction of movement.

A short arrow = taking direction (→ up to 10°, ↗ up to 30° and ↑ up to 90° to the direction of movement).

Time Exposure	Tripod Pictures:					Hand-Held Pictures:				
	Slow Speeds					Fast Speeds				
B	1	1/2	1/4	1/8	1/15	1/30	1/60	1/125	1/250	1/500 sec.

The Shutter Speed

The single lever Synchro-Compur shutter is a between-the-lens shutter with combined lever for tensioning and releasing, employing the above mentioned speeds. 1/60th sec. represents the most commonly used instantaneous shutter speed, with little risk of camera movement. Shutter speeds longer than 1/30th sec. are most advisedly used only with a tripod. To minimize or avoid unsharpness due to subject movement: see table page 23.

The shutter speed values appear in the indicator window to the right above the taking lens. Read them as denominators of the fraction values, i. e. 30 = 1/30 sec.

Intermediate scale settings between engraved values are not possible. Because of the shutter speed-diaphragm coupling it is better to set the shutter speed first, before the diaphragm opening, to avoid unintentional change of the diaphragm's position.

Setting the Shutter Speeds: by means of the shutter speed lever ①a. Watch diaphragm coupling!

The Light Value

is indicated by the movable mark on the light value scale. For details on use of the light value system: see page 26.

Setting the Light Value: Adjust shutter speed lever ①a and diaphragm lever ①b at the same time.

To change shutter speed and diaphragm combination, while maintaining same light value: Move shutter speed lever ①a only.

The Double Exposure Prevention Lock

is engaged with the lever in the upper position ②a and is disengaged in the lower position ②b. When released, the red mark (otherwise covered) acts as a warning signal: "Beware of unwanted double exposure!"

Engage the lock when using roll film,

disengage when using RolleiKin 2, plate adapter back or when making intentional double exposures (p. 10).

Re-engage the lock after completing a double or multiple exposure, before re-tensioning shutter.

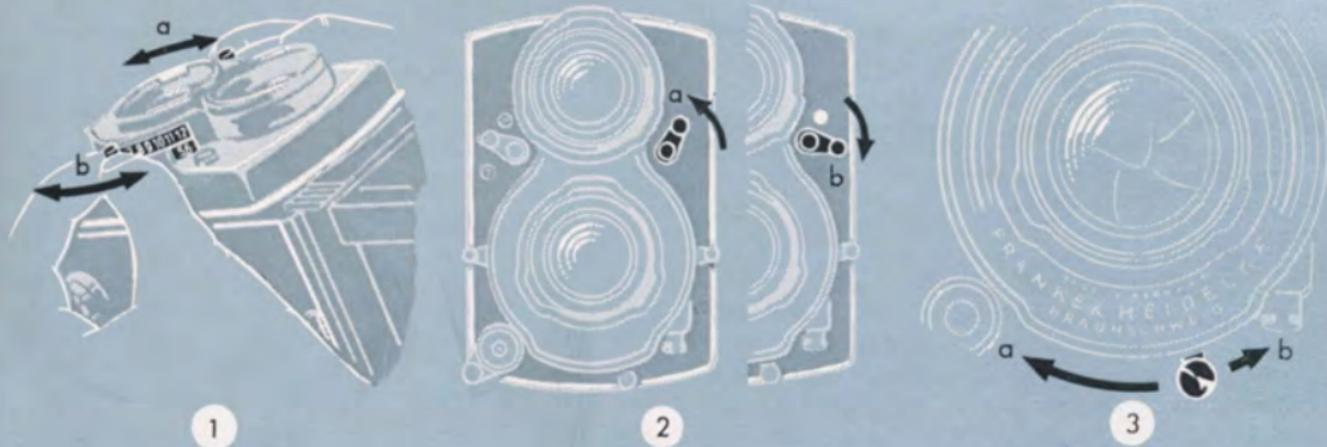

Tensioning and Releasing

The shutter lever serves alternately as both cocking and releasing lever. A cable release or the Rolleicord accessory body release may also be used.

Tensioning: move lever to the right as far as it will go ③a and then back to original position.

Releasing: gently move lever to left until shutter click is heard ③b.

Time Exposures: set shutter speed control to B and move shutter lever to left ③b, holding for required time. Releasing the lever closes the shutter. To avoid camera movement during time exposures, use a locking type cable release.

The shutter and self-timer may be left cocked even when the camera is laid away for short periods of time without weakening the power of the springs.

Brightness →

Light value

Shutter Speed

← Subject Motion (Page 23)

Diaphragm Opening

← Depth of Field (Page 19)

Exposure and Light Value

Correct **exposure** is dependent upon existing illumination (more exactly: subject brightness). The **light value** indicates the correct exposure. A reading is taken from the exposure table or a photo-electric exposure meter set for the proper film speed and then transposed to the light value scale of the camera. The shutter speed and diaphragm opening relationship are thus adjusted at once for the correct exposure.

This correct relationship between the shutter speed and diaphragm opening is automatically maintained by the coupling mechanism even when another speed-diaphragm combination is sought to obtain a certain depth of field (see table). For this only the **speed** lever is employed. Thus it is possible to quickly choose the most suitable of the possible combinations, without calculations and without changing the basic required exposure.

The light values 13 to 9 permit a choice from six shutter speed and diaphragm opening combinations, ranging from f:4 to f:22, for example, light value 13:

Shutter Speeds	1/500	1/250	1/125	1/60	1/30	1/15
Diaphragm Openings	4	5.6	8	11	16	22

If the „B” setting appears when choosing the shutter speed-diaphragm combination it will indicate that double the next previous setting is required, or 2 secs. Exposure time is doubled for each smaller diaphragm opening. For example, light value 6:

Shutter speed	1/4	1/2	1	(2)	(4)	(8)
Diaphragm opening	4	5.6	8	11	16	22

Intermediate values may be used on the light value scale. In such cases between-figure diaphragm positions will result, although automatic coupling in the proper relationship will still be maintained. f:3.5 is itself an example of an intermediate stop, positioned between f:2.8 and f:4 of the international diaphragm scale.

The **exposure table** with its light values has been designed for use with most often met with lighting conditions and serves to prevent serious errors. In difficult cases or for greatest accuracy, it is advisable to make use of a photo-electric exposure meter. If the meter is not calibrated for light values, shutter speed and diaphragm scales are set separately. Thus the correct light value will be indirectly ascertained and changes to other combinations may be easily and quickly made in the previously described manner.

General Exposure Rule: It is not always possible to pair a sufficiently fast shutter speed (to minimize effect of subject motion) with a small diaphragm opening (for greater depth of field). Obviously a compromise is required and it would be well to remember that under-exposure results in hopelessly lost shadow detail, whereas over-exposure may be compensated for to a great extent by proper processing. Therefore: a good general rule for exposure:

Always expose for the **shadows**, rather a bit **more** than too little!



Film Speed Reminder ASA/DIN

So that one may know at all times the speed of the film in the camera, a simple reminder, showing both ASA and DIN speeds is located in the outer part of the focusing knob. This is especially valuable when frequent changes of film material are made. Values range from 8 to 160 ASA and 10/10 to 23/10° DIN.

Setting the Film Reminder: Press knob in center of disk and turn to desired value.

A

B

C

D

E

ASA					DIN		
12	12	11	10	9	8	12	
25	13	12	11	10	9	15	
50	14	13	12	11	10	18	
100	15	14	13	12	11	21	
	± 0		-1		-2		
	-1		-2		-3		

Explanations of the Picture Examples:

A
High mountains (snow) without foreground.
Open beach.

B
Sport scenes.
Bright streets and squares, open landscapes.

C
Landscapes with foreground.
Groups in open air.

D
Groups in shade.
Street scenes with shade.

E
Groups under trees, lightly shaded.
Groups in glass-roofed halls.

The Exposure Table

Subject brightness is easily judged and classified by means of the five standard lighting conditions represented by two illustrations each at the top of the table.

Film speed is indicated at the left by ASA figures and at the right by $1/10^\circ$ DIN values.

Light value is found where brightness and film speed columns cross.

Light value adjustment, due to overcast sky or when sun is lower in the sky, is made by use of lower scale. Upper scale: full sunshine - lower scale: overcast sky. The length and intensity of your own body's shadow will give some idea of light conditions. The ability to estimate and choose the correct light values for various lighting conditions and time of day will soon come when you begin working on sunny and cloudy days.

Example: Color film 25 ASA ($15/10^\circ$ DIN), landscape with foreground, sunny, noontime (shadows short, no light value adjustment): light value 11. Available speed-diaphragm combinations: $1/125 - f:4$, $1/60 - f:5,6$, etc. Same subject in the afternoon, longer shadows, would require adjusted value, perhaps $11-1 = 10$.

Speed of Photographic Emulsions

(Comparison values approximated)

Relative exposure	DIN	Scheiner (Europe)	ASA (BS)	General Electric	Weston
8	7/10	18	4	4,5	3
7	8/10	19	5	—	4
5	9/10	20	6	7,5	5
4	10/10	21	8	9	6
3,3	11/10	22	10	12	8
2,7	12/10	23	12	15	10
2	13/10	24	16	18	12
1,7	14/10	25	20	24	16
1,3	15/10	26	25	30	20
1	16/10	27	32	36	24
0,8	17/10	28	40	48	32
0,67	18/10	29	50	60	40
0,5	19/10	30	64	75	50
0,4	20/10	31	80	100	64
0,33	21/10	32	100	120	80
0,25	22/10	—	125	150	100
0,2	23/10	—	160	200	125
0,17	24/10	—	200	250	160

The characteristics of the different rating systems do not permit a direct mathematical conversion. However, the approximate comparison values of the table offer sufficient information for most practical purposes.

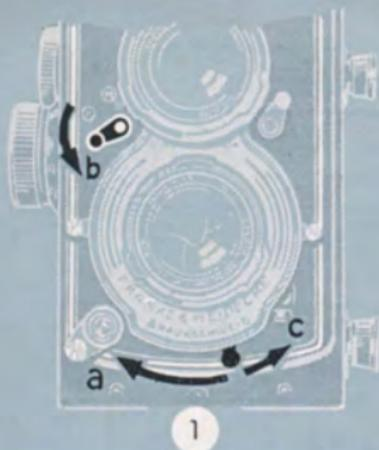

Self-timer

When using the self-timer, approximately ten seconds will elapse before the shutter is released. All speeds, 1 to 1/500th sec. may be used, but "B" setting cannot be used. Cocking of the self-timer mechanism is possible only after shutter is tensioned and is accomplished by moving Synchro lever to V ①b. Shorter delays of less than ten seconds may be obtained by setting the Synchro lever to an intermediate position between

X and V. After releasing the shutter the lever immediately snaps back to X ②. This indicates that the self-timer mechanism is running and also shows that the X setting is the only possible one for self-timer flash shots; see page 35. Self-timer flash exposures must be calculated for X setting since M-contact cannot be used.

To Use: cock shutter ①a, set Synchro lever to V ①b and release ①c.

III. FLASHLIGHT TECHNIQUE

In modern flashlight technique the camera shutter takes over the task of firing the bulb electrically at the right moment. In this way instantaneous flash exposures are possible with a hand-held camera.

The Synchro-Compur shutter in the Rolleicord is, for this purpose, equipped with electrical contact. The contact may be adjusted to the required delay of the flash lamps by means of the Synchro-lever:

The **X-contact** ② presents the simplest type of contact (zero-delay). It is required for zero-delay electronic flash units (without relay) and a few flash lamps.

The **M-contact** ③ means full synchronization. It works with most flash lamps and the electrically fired flash powder (capsule flash). The most important advantage of the M-contact: with certain flash lamps it may be employed at the shorter shutter speeds even including 1/500th sec. Due to the full synchronization the shutter is always open when the flash emitted by the lamp reaches its peak intensity.

Thus all types of instantaneous flash exposures are possible with the Rolleicord.

The selection of flash lamp-type depends on the light output required by the subject. Many makes are available in three groups (normal, medium and high light output). The selection is dependent on the taking conditions, especially as to whether a room of shallow or great depth is to be illuminated.

Selection of M-X lever position, applicable speed range and exposures can be learned from the instructions of the different flash light products. For the best known makes the table on page 32 contains the necessary information and the permissible shutter speeds.

Use: The flash attachment is connected to the camera by means of the flash cable, plugging into the special socket provided therefor.

Move Synchro lever to X ② or M ③

To release the flash cord plug: unlock by swinging locking lever ④

Flash Contact and Permissible Shutter Speeds

FLASH LIGHT SOURCE		Contact	Shutter Speed: Fastest Slowest Recommended
Make	Type		
I. Electronic Flash			
	Without Relay		
General Electric Westinghouse	SM	X	1/500 1/250 1
Sylvania West, Japan	SF SS	X	 1/60 1/60 1
Osram West, Japan	F0 F1, F2 XP, X0 12	X	1/30 1/30 1
II. Flash Lamps			
Osram	S2 S0, S1	M	1
Philips (Mazda)	PF 3 N, PF 14, PF 25, PF 56	M	 1
General Electric Westinghouse	5, 11, 22	M	1/60 1
West, Japan	0, 3, 5, 11, 22 Press 25, 40, 0, Bantam 8	M	1/60 1
Sylvania	2	M	1/60 1
Philips (Mazda)	PF 110	M	 1
General Electric Westinghouse	50	M	1/60 1
Sylvania	3	M	1/60 1
General Electric Westinghouse West, Japan	6, 31	M	1/60 1
Sylvania	FP 26, 2A	M	1/60 1
III. Cap: etc Flash		M	1/60 1
	Average	M	1/60 1

Explanation of the Table

The "**Contact**" column indicates the correct setting of the M-X lever for each lamp type.

The "**Shutter Speed**" column shows the permissible speed range:

Center: the recommended shutter speed includes practically the entire light output of the flash lamp. This assures the maximum illumination as well as the smallest diaphragm (for greater depth of field). The following applies as a general rule:

Use the standard recommended speed together with the correct setting of the M-X lever for the lamp in use.

Left: the fastest speed indicates the limit to which the shutter may be set. For lively action or sports subjects, the faster speeds are employed.

Right: the exposure time may be increased to the slowest speed (1 second or even time exposures), if, in addition to the flash, it is desired to make use of existing light. In such cases the total amount of

light from all sources must be considered in choosing the diaphragm opening.

The **Effective Exposure Time** (as indicated in the table by means of colored ink) is not in each case identical to the shutter speed, but depends on the portion of the flash lamp light output utilized:

With X-Contact the duration of the flash itself is actually shorter than any of the permissible shutter speeds. Therefore, the light duration of the flash (specified in parenthesis after the make) will be the actual, constant exposure time so that the selected diaphragm opening must be maintained even when using slower shutter speeds.

With M-Contact the shutter speeds, from "fastest" to "recommended" fall within the duration of the flash: they therefore represent the actual exposure time and if the shutter speed is increased, the diaphragm must be opened accordingly. Only when slower shutter speeds are employed is the fully utilized light output equal to the actual exposure time, and this is the same as the recommended speed.

The illustration should make the utilization of the available flash light still more obvious: the white symbols represent the flash, and their size, the utilized light at the shutter speed employed.

How the Flash Contacts Work

The information given thus far is entirely sufficient for normal purposes and is adequately supplemented by the exposure tables usually furnished by the various flash lamp manufacturers.

The photographer who is familiar with and habitually makes use of flash lamp graphs should know something about the method of operation of both flash contacts.

X-Contact (zero-delay): contact is made shortly before the shutter blades reach full opening. Application: for lamps with short firing time (up to 5 milliseconds) and short flash duration.

M-Contact (full synchronization): contact is made approximately 16.5 milliseconds before the shutter blades are fully opened. Application: for flash lamps with long firing time (average firing delay 16.5 milliseconds) and long light duration.

For safety reasons one pole of the contact is grounded to the camera body (isolation-test: 700 volts). All commercially available flash guns and electronic flash units may be used. Current-carrying capacity of the contact when several flash lamps are connected simultaneously: 10 ampères at 24 volts for a period up to a maximum of 1/10th sec.

Tips on Flashlight Photography

1. Use fresh batteries. Condenser or capacitor flash-guns are more consistent since lamp ignition is somewhat less dependent on battery power (Rolleiflash).
2. Be sure that the contacts of the battery and lamp sockets are clean. Handle flash cable with care, avoid kinking, otherwise there will be danger of short-circuit and premature flash ignition. - Note: the contact must not be connected to house current!
3. To light up long rooms or to achieve special illumination effects, one or two Rolleiflash-Comb. extension units may be connected to the Rolleiflash. Connecting cords adding up to a total length of 33 feet (66 feet with fresh battery) may be used. Always insert flash lamps in Rolleiflash first, then in extension units, to avoid premature firing. Unnecessary battery drain will be avoided by inserting lamps just before firing and ejecting immediately afterwards.
4. Blue flash lamps, like electronic flash, simulate daylight and are intended for use with daylight color film.
5. The power of flash illumination decreases according to the square of the distance: i. e., an object six feet away receives only one-fourth the light as an object

at three feet. Distance from flash to subject must therefore be carefully considered in selecting diaphragm opening. Lamp manufacturers supply easy to use guide numbers which are divided by the distance in feet to obtain the required diaphragm opening.

6. Flash as main light source: do not take weak room illumination into account, expose strictly according to flash output.

7. Flash as fill-in light: useful in brightening shadows whether due to insufficient illumination or to the fact that the picture is being taken "against-the-light", in full sunlight. The fill-in light must be kept at a lower intensity level than the main source of illumination, otherwise the strong flash will give an unnatural effect, not at all like daylight. Too strong a flash might even cause an apparent underexposure of the sky or the area not reached by the light. Electronic flash units are particularly well suited for use as fill-in lights when shooting color sports pictures. Use smaller lamps or keep them at greater distance.

8. When using the built-in self-timer, only X-contact is employed. It is best to use 1/30th sec. with this contact setting for most lamps.



1:4
electronic flash





IV. LOADING AND FILM TRANSPORT

The Rolleicord is designed for use with No. 120 or B II 8 (not 620) roll film and delivers twelve $2\frac{1}{4} \times 2\frac{1}{4}$ pictures.

The loading of the camera is divided into the following operations: open the back, insert the full film-spool, wind film to set indicator marks opposite red dots, close the back. Continued advance of the film is accomplished through rotating the film winding knob until it stops.

Back

To Open: swing aside the back locking lever at the bottom of the camera ①, lift the clip ②, open back ③, using the clip as a handle.

To Close: with the flat of the hand push the back closed, fold down the clip and return locking lever to full forward position.

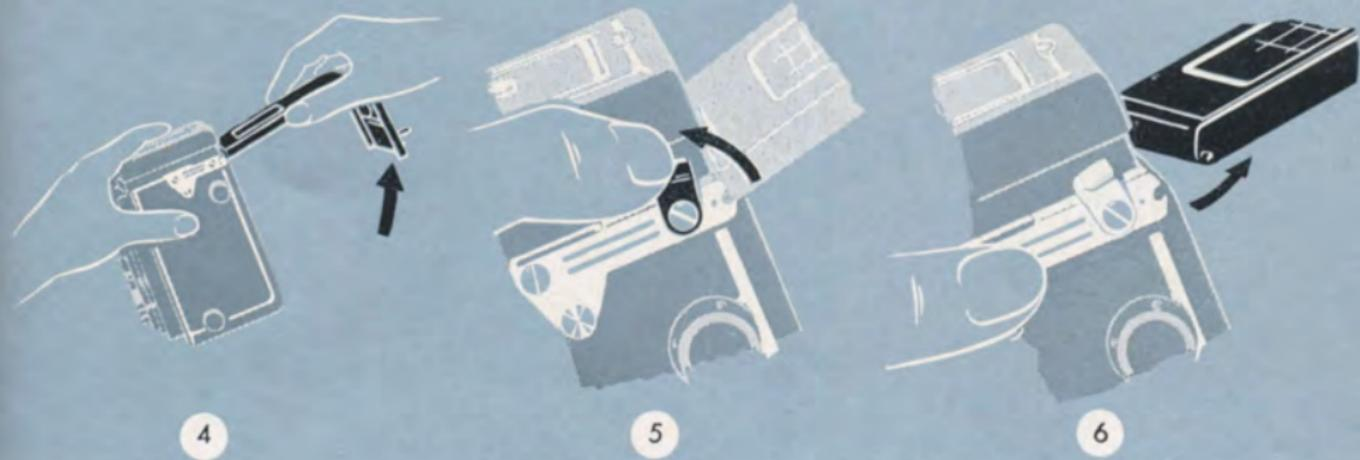

The back of the camera is generally removed only when replaced by the plate adapter.

To Detach: open back wide ④ and swing locking lever on the left hand back hinge upwards ⑤. Remove back from hinge on this side ⑥.

To Attach: fit back first to right hand hinge, then to left hand (slotted) hinge, and lock.

The plate back adapter is also attached to the camera in this manner.

Protect the open camera against prevailing dust and dirt and clean it occasionally with a soft camel's hair brush!

Never change film in direct sunlight, utilize at least your own body's shadow!

The camera may be attached to a **tripod** by means of the threaded socket on the bottom. **Caution:** the length of the tripod screw must not exceed 3/16". If longer, employ a washer or spacer to avoid damage to camera. For cameras with continental tripod sockets a reducing bushing is available.



Film Pressure Plate Must be Positioned Correctly!

When roll film is employed, the inscription $2\frac{1}{4} \times 2\frac{1}{4}$ " must be visible below the film pressure plate. When changing from 120 roll film to 35 mm. film, or the reverse, an adjustment must be made according to the film type being used.

To adjust the film pressure plate ①: press the plate against the back and push it up or down until it stops. When released it must spring forward completely into the normal panel

Inserting the Film Spool

In the factory-new camera the empty spool (take-up spool) is already in position. After removal of the exposed film the just emptied spool becomes a take-up spool, and must be transferred to the upper spool-chamber. The end with the slot goes to the right engaging the winding key of the film transport mechanism ②.

Film spools are held on either side by suitable metal plugs which act as bearing surfaces. Change films by pulling out spool knob on the side of camera. This



4



5

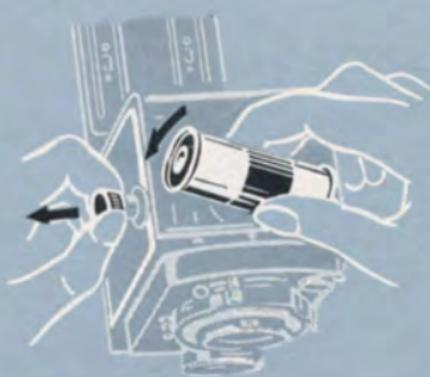

6

retracts the inner plug and releases spool, which pops up due to spring pressure. Care must be taken to avoid pulling out spool knobs and thus dislocating film spool before all exposures have been made and film fully wound.

To Insert the Empty Spool: first fit the spool over the winding key on the right (winding knob side) and pull out the take-up spool knob ③. Push spool down on the left so that the knob may snap back into place fully ④. It is then necessary to turn the winding knob until the long slot in the empty spool comes uppermost ⑤.

Note: when using the plate adapter the empty 120 (or B 2) spool is removed from the camera. However, it must be handily retained especially on trips, since otherwise a new roll film cannot be loaded into the camera.

To Insert a Full Film Spool: in the same way as applies to the take-up spool ⑥. The pointed end of the backing paper must point in the direction of the take-up-spool chamber, so that the colored side of the backing paper remains on the outside.



1



2



3

Starting the Film

After inserting a full film spool break the seal and remove it.

1. Pull the beginning of the backing paper up to the take-up spool, printed side outwards, and insert the tapered end into the long slot of the take-up spool as far as it goes ①.

2. Wind up the backing paper by turning the film

winding knob until the triangular marks (or double arrows) are in line with the red indicator marks on both sides of the film aperture ②. Check to see that film pressure plate is in correct position and wind film evenly, using thumb as a brake.

Close the back, and lock.

Engage double exposure prevention lock.



4



5



6

Advancing Film

Turn winding knob until it stops ③
(The shutter tensioning and release lever thereby remains in "rest" position.)

Removal of the Film

After the 12th exposure: wind off the film with some six complete revolutions of the winding knob ④.

Removal: open back in shady spot, pull out take-up spool knob and lift film out from left side ⑤. Fold under a good portion of the backing paper (for easy opening when developing) and seal with tape ⑥. Put the exposed film back into the light-proof protective cover of the original package!

Never change film in direct sunlight! Utilize, at least, the shadow of your own body.

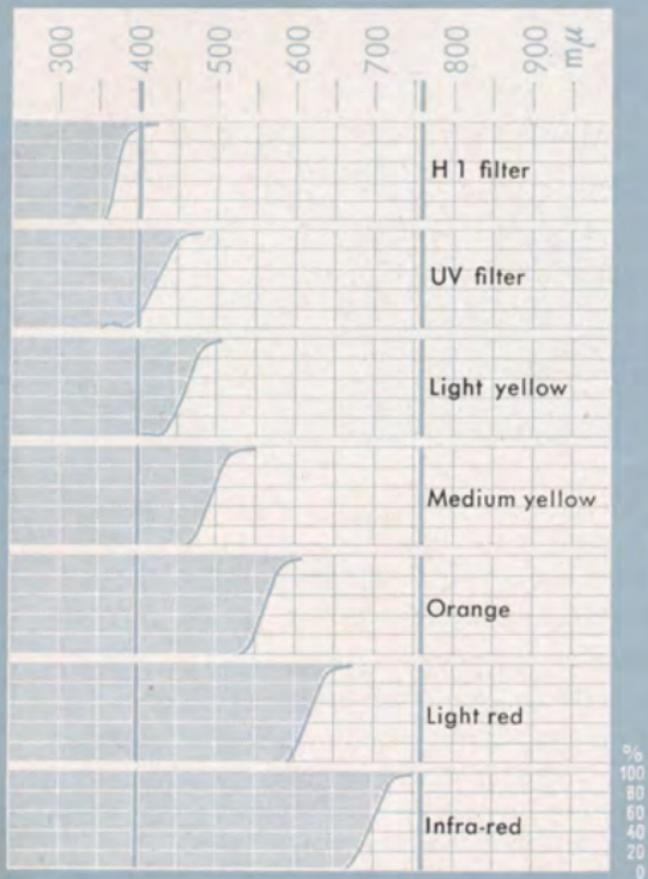

V. TIPS ON PICTURE-TAKING

Landscapes

Focusing for distant views with foreground may be accomplished simply without using ground glass except for viewing: set infinity mark (∞) opposite diaphragm opening used - second corresponding diaphragm mark will indicate nearest point in focus. Example: ∞ at $f : 11$ - sharp area ∞ to 17 ft (5 meters).

Filters: important for separating tones, which would otherwise be similarly rendered by the black and white film, or for influencing the mood of the picture.

1. Blue sky with clouds: yellow filters darken blue skies and thus improve the reproduction of clouds. The deeper the color of the filter, the stronger and more dramatic the effect. Blue snow shadows are also rendered truer to tone. The green filter tones down the sky, brightens foliage and darkens the occasionally too lightly rendered reds (with pan film) such as sun-tanned flesh and red tile roofs.

For filtering the sky but not the landscape: the Rollei-pol filter darkens the blue sky only by eliminating the polarized light.

2. **Haze and mist:** the blue filter, useful for pictorial effects, increases hazy effect. The orange or red cut through and improve the clarity of distant views. The blue filter reduces contrast, the red or orange increases brilliance. Maximum penetration of light haze is obtained with infra-red film and infra-red filter (700 $m\mu$). Barely visible mountain chains are reproduced clearly. An odd effect with this combination is that green leaves are rendered almost white. Filters are of no use at all in really bad weather when there is a considerable amount of moisture in the air.

3. **Sea, Beach, Mountains:** strong ultra-violet rays must be absorbed through use of U.V. filter. Results will otherwise be dull. The H 1 filter serves the same purpose for daylight-color film. Reduction of the bluish cast is quite marked.

Picture composition rules: distant views are generally better if foreground contains (for added depth impression) trees, people, animals, etc. Foliage is often used as a frame for the distant view. Focus should be sufficiently sharp in the foreground. Strong effects are created when deep shadows in the foreground are set against the lighter distance. Side lighting or even back lighting gives the most impressive pictures.

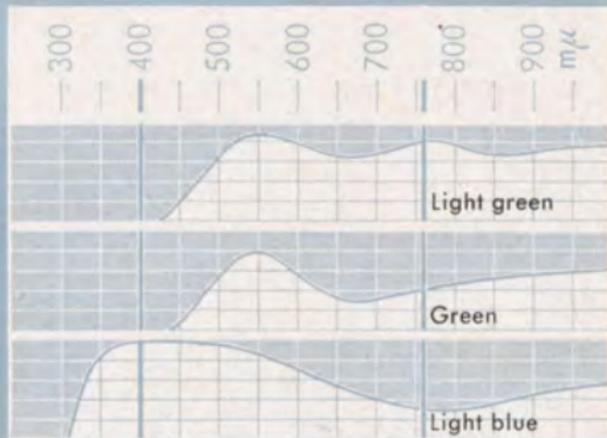

The filter curves show the absorption of the various Rollei filters in the spectral ranges ultra-violet, visible spectrum blue to red (appr. 400-760 $m\mu$), and infra-red. This means: darker portion of the spectrogram = absorbed light; lighter portion = useful light. The light-transmission of the filter from the lowest point to the peak point of the curve thus increases from 0 to 100%. While the H 1 filter cuts out the short wave ultra-violet portion of the spectrum, the green filter absorbs a substantial portion of the long wave red and infra-red range.



1:8 · 1/125



Portraits

Large heads: do not work closer than **40 inches** to avoid possible perspective distortion. If necessary, enlarge from a smaller section or use Rolleikin. Focus on the eyes. Use quiet, neutral colored backgrounds and do not stop down too much (f:5.6) so as to keep backgrounds from intruding. If possible, move subject away from background. Out of doors, try using sky only as background. Open air portraits are best taken early or late in day when light is softer and not too blinding. Favor soft light, avoid deep shadows. In emergencies use reflectors or fill-in flash. Simple, proven artificial light procedure: lamp No. 1 next to camera somewhat above head level, lamp No. 2 on the side to lighten shadow, approximately 1/30th sec. For special effects, lamp No. 3 as overhead or back-light. Important: use lens hood and focusing extension hood for reducing extraneous light. Pan film, no filter. Moisten lips (highlights!). To reduce sharpness and add "glamor": Rolle soft diffusion disc 0 or 1 (stronger) over lens. Use larger diaphragm openings and backlight for sunny effects.

Children

Never use force, watch for interesting effects and expressions carefully. A clever assistant to divert children's attention from camera is often a valuable aid. Try close-up shots of children's expressions as they listen to favorite or exciting stories. Laughter, astonishment, pity and even an occasional yawn provide wonderful material for good shots or picture series. For close-up shots use same technique as for portraits. For children in motion, use snapshot technique outdoors and flash indoors. Low viewpoints and close-up effects are best.

Animals

Patience, quietness and familiarity with the animal and its peculiarities are great assets. Close-up pictures are most rewarding; use portrait technique. Make use of natural light effects such as backlighting. Action pictures: use snapshot or sport technique (with flash, if needed). Rolleinars are often helpful with small animals. Zoo: animal portraits – avoid bars or netting. Hint: netting often becomes invisible when lens nearly touches wire. – Fish in aquarium: use side and overhead lighting in otherwise darkened room. A good trick is to limit movement of fish within sharp zone by means of vertical glass plate in tank.



1:4 · 1/60
Rolleisoft 0





1:11 • 1/60 • filter light yellow

Snapshots

Unexpected picture opportunities or rapidly changing subject distance make a simplified technique, based on depth of field zones, highly desirable. The following three settings have been found very effective:

1/125 sec.

Diaphragm opening f: 8

Short distances

Medium distances

Long distances

approx.

approx.

approx.

9 to 18 ft

13 to 33 ft

18 to 100 ft

12 ft

20 ft

30 ft

Shutter speeds and diaphragm openings do not often need changing in sunlight. Those suggested cover most contingencies. Thus instead of wasting time focusing when in a hurry, use one of the above settings. This snapshot technique is especially useful with the direct view finder. Variation of the values (see table, p. 21) makes this technique available for other depth of field zones. Example: diaphragm opening f:11, focus at 30 ft, depth of field extends from 15 ft to ∞ for snapshots of scenes. Chief uses for this technique: groups in motion, sport scenes, playing children, reportage, sports.

Sports

Sports pictures are generally most effective when the original rapid motion has been sufficiently "arrested" and the subject remains well defined. The fastest shutter speeds are essential, together with careful focusing. Sometimes pre-focusing on the spot where the action is to take place is possible. Do not overlook the possibilities of training sessions, since greater cooperation can often be had at such times. Snapshot technique is valuable for turf and ice shots and for any case when it would be difficult to guess exactly where to focus. Watch your shutter speeds and viewing angle. Shooting at right angle to the direction of the action requires a much faster speed than when the action is going in other directions (see table page 23). If the action is very fast or takes place close to the camera, it is best to pan or follow with the camera. This results in a sharply rendered main object against a blurred background, thus increasing the impression of speed. There is often a fine moment for shooting when the action reaches a peak and stops momentarily, such as when a pole-vaulter "hits the top" before starting to come down again. With insufficient light or indoors use synchro-flash and 1/500 th sec. The extremely short duration of electronic flash is highly desirable in some instances. Use the direct view finder; do not overlook the advantages of the Rolleikin with its telephoto effect, maximum use of film oval and greater film capacity.



1 : 4 . 1/250

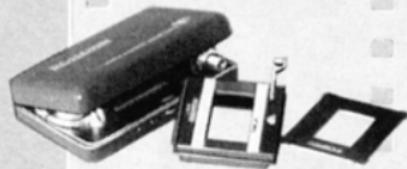

Theatre and Music Hall

At longer distances only a section of the film is generally used hence this is a good field for using the Rolleikin. Do not depend on footlights but concentrate on spotlighted performers or features. Exposures of 1/30th sec. are generally adequate under the strong lights with fast pan film. To take flash pictures without knowledge of or disturbing subjects: use dark flash (colored lamps or reflector with infra-red filter) and infra-red films. After pre-setting focus you can use direct view finder most comfortably.

Night

Include direct light sources as symbols of the night in the picture. Only very strong, close lamps must be hidden behind natural foreground objects (building, tree, persons), otherwise overexposure will result. Make use of effects: reflections in wet streets, light deflected by snow, early twilight with traces of brightness in the sky. Use fast pan film only. For time exposure: cover up lens when auto headlights cross the picture area, to avoid streaks. Use flash for snapshots at night, not for night shots.

Copying

Smaller originals are best copied with Rolleinar. See table page 55 for reproduction sizes. The camera should be set on a rigid, vibration free stand with the original parallel to the film plane. Use a small stop; $f:11$ recommended. Light evenly from both sides but avoid reflections. Glossy surfaces give less trouble if Rolleipol is used. Colored originals may require filter for better tone separation. Use contrasty ortho film (or even positive film with Rolleikin) for black and white originals. Spots on originals can be minimized by using a filter similar in color to spot with pan film. The Rolleikin is especially valuable for series or archive work. Single reproductions are economically taken with the plate back adapter. Reproductions from books are readable with ordinary magnifier directly from $2\frac{1}{4} \times 2\frac{1}{4}$ contact prints. Small objects (small machine parts, assembly pieces) may be handled similarly to copying. A spotlight can often be an additional aid in this case. Shadowless lighting effects are facilitated by placing object on a suspended glass plate. Reflections from fine glassware or other highly reflecting objects can be reduced to a minimum, if the object is photographed by reflected light such as can be had inside an illuminated, white painted box.



1:8 · 1/60

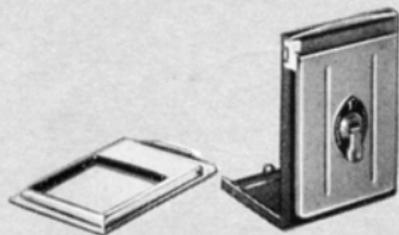



Rolleipol



Shiny Surfaces

Eye-glasses, pictures, water surfaces, window glass and other brilliant reflecting surfaces often give disturbing reflections, not always avoidable by changing angle or illumination. A simple remedy in many cases is to use the polarizing filter Rolleipol. Reflected light is often polarized in one direction and this can be absorbed or reduced by proper orientation of the Rolleipol. This is done by merely turning it for best effect. It may sometimes be necessary to change camera position to obtain best angle. In artificial light a second pola-filter over the light gives full control at any angle. When the reflections are removed objects seen through the shiny glass or water surfaces become clearly evident. Torsion or strain tests of various materials are also possible with the help of the Rolleipol. Reflections from certain metal surfaces when the Rolleipol has little or no effect are best handled by photographing in diffused light or changing direction of illumination. Small, shiny metal parts can be held over burning magnesium to provide a white coat or greased and rubbed with graphite.

Plants

Flowers, blooms and grass are most effective in close-ups taken against the light. Use Rolleinars with fill-in light or reflectors. Stop down for needed depth of field and shoot in bright light with no wind. A semi-circular shaped cellophane shield is an effective guard against the ground breezes that destroy definition. Use filters to differentiate between equally bright colors. Keep in mind that a filter renders its own or similar colors lighter, whereas its complimentary color comes out darker.

Color Photography

Color films have little exposure latitude, so avoid strong light contrasts and use exposure meter. In doubtful cases make three exposures, varying diaphragm opening one half stop each side of what is considered normal. Correct color reproduction is possible only with correct matching of proper film types with illumination. Use compensating filters when needed according to manufacturer's instructions. Rolleipol-Filter: reduces glare from reflecting surfaces, also darkens the blue color of the sky (page 42) without affecting the color of the landscape. Select subjects with pleasing large color patches, not just an accumulation of loud colors. Overcast sky often renders pleasing pastel effect.



1 : 8 · 1/60 · Rolleinar 2 · filter green



Pictures Through the Microscope

When a microscope is focused by someone with normal eye-sight, the eye sees the image as if it were at infinity. Consequently, the Rollei, also focused at infinity, can simply take the place of the eye over the microscope in order to record the image on film.

Microscope and camera should be mounted on firm stands, without mechanical connections. Place the camera so that taking lens, focused at ∞ , is brought as close as possible to the ocular. Check optical axis carefully; film plane should be parallel to surface being photographed. For full coverage of $2\frac{1}{4} \times 2\frac{1}{4}$ use wide angle ocular, however, sufficient coverage for Rolleikin negative is to be had in any case. Framing through view finder is unnecessary. Do not stop down since this has no effect on exposure. Factors affecting exposure are illumination and transmission of the objective, to be ascertained through tests. Apochromatic micro-lenses are best, particularly with color film. In shooting black and white with these lenses, use ortho material and green filter. Generally interesting are micro-pictures of crystallized chemicals through Rolleipol filter in conjunction with another pola-filter over microscope condenser.

Care of the Rolleicord

A precision camera demands care in handling. Protect it against moisture, dust, sand, strong sunshine, hard blows or falls. First safeguard: the ever ready case. Second safeguard (when not in use while travelling): a rubber bag to guard against water, sand or snow. Carry camera around neck to minimize transportation shocks. Keep all parts clear and clean lenses with a soft camel's hair brush or doeskin. Although the mechanism is not unduly sensitive to cold, some condensation may form on the lenses when the camera is brought into a warm room from outside in cold weather. Do not wipe off - let moisture evaporate. In the tropics arrange to keep the camera, when not in use, in an air-tight container.

In Case of Damage to the Rolleicord

The task of repairing major or minor damage is the special province of the expertly trained mechanic. Franke & Heidecke maintain their own special workshop in which all repairs are done with precision at nominal prices. Abroad, apply to photo dealers and factory representatives for full information.

The Practical Accessories for the Rolleicord V

Code:		Code:	
Becor	Ever Ready Case for Rolleicord V	Etset	Leather Case containing: 1 Lens Hood and your choice of 2 Filters
Baobe	Lens Hood		
Baihe	Rollei Yellow Filter, light	Etsof	Leather Case only
Baimi	Rollei Yellow Filter, medium	Focom	Complete Plate Adapter Equipment comprising: 1 Plate Adapter, 3 Slides, 1 Focusing Screen Slide, 1 Leather Case for 2 Slides
Balin	Rollei Green Filter, light		
Baeen	Rollei Green Filter	Foapt	Plate Adapter
Basky	Rollei UV Filter	Fosli	Slide
Baora	Rollei Orange Filter	Fopla	Cut-Film Sheath
Baubi	Rollei Red Filter, light	Focas	Leather Case for 2 Slides
Babla	Rollei Blue Filter, light	Fofoc	Focusing Screen Slide
Bahaz	Rollei H 1 Filter (UV Filter for Daylight Color Photography)	Rolki	Rolleikin 2
Bafir	Rollei Infra-Red Filter	Foead	Panorama Head
Batnu	Rolleisoft 0	Fohod	Extension Hood
Baton	Rolleisoft 1	Fogri	Rolleigrd Lens
Batar	Rolleipol	Corel	Body Release
Bapun	Rolleinar Lenses, set 1 (40-18 in.)	Basyn	Rolleiflash Attachment
Baken	Rolleipar Lens 1	Boxin	Boxin Case for 1 Rolleiflash + 1 Rolleiflash-Comb.
Baodo	Rolleinar Lenses, set 2 (20-12 in.)		
Bakdu	Rolleipar Lens 2	Cekab	Extension Cord for Flash-Attachment 10 ft.
Etcom	Leather Case containing: 1 Lens Hood, 2 Sets of Rolleinar Lenses, 2 Rolleipar Lenses and your choice of 5 Filters	Flaco	Extension Flashholder Rolleiflash-Comb. with Connecting Cord 80 in.
Etlee	Leather Case only	Trika	Extension Cord for Rolleiflash-Comb. 10 ft.
		Blika	Flash Connecting Cord 32 in.

To avoid errors when ordering accessories please specify camera-number.

Full information on the use of Rollei accessories in the booklet "The Practical Accessories".

Table of Rollei Filters

The filter factors indicate average values which, however, may be changed according to the particular type and make of film used and the light conditions.

Rollei Filter	Use	Filter Factor	
		Ortho	Pan
Light yellow	Landscapes, snow, clouds. Renders yellow and green lighter, blue darker.	3 x	2 x
Medium yellow		4 x	3 x
Light green	Landscapes, snow, clouds. Renders green lighter, red (complexion) and blue darker. For pan emulsions.	3 x	2 x
Green		4 x	3 x
Orange	Hazy distant views. Renders yellow-red lighter, blue darker, distant objects clearer.		3-7 x
Light red	Hazy distant views. Renders red lighter, blue-green darker. Gives stronger effects than Orange Filter.		4-10 x
Light blue	Artificial light. Renders red darker. For ultra-pan emulsions.	1.5 x	1.5 x
UV	High altitudes above 6000 feet. Seascapes. Eliminates ultra-violet rays which reduce contrast.	1.5 x	1.5 x
Infra-Red	Special filter for infra-red emulsions. Transmits dark red above 700 m μ and infra-red.	*)	
H 1	UV-Filter, especially designed for long distance color photography. Absorbs ultra-violet rays, subdues predominance of blue and cuts aerial haze in distance shots.	No increase of exposure	

*) Exposure depends on the type of emulsion used and must be determined by tests.

Focal Length and Focusing-Range with Rolleinar Lenses

Rolleinar Lenses	—	1	2
Focal Length	75 mm	71 mm	68 mm
Focusing-Range in inches)	∞ — $35\frac{1}{2}$	$39\frac{1}{2}$ — $17\frac{3}{4}$	$19\frac{3}{4}$ — $12\frac{1}{9}$

Field-Size and Scale of Reproduction

Focused Distance		$31\frac{1}{2}$ in.	$19\frac{3}{4}$ in.	13 in.
Field-Size (in inches)	$2\frac{1}{4} \times 2\frac{1}{4}$	22 x 22	$13\frac{3}{4} \times 13\frac{3}{4}$	$8\frac{3}{4} \times 8\frac{3}{4}$
	Rolleikin	$9 \times 12\frac{1}{8}$	$5\frac{1}{2} \times 7\frac{7}{8}$	$3\frac{1}{2} \times 5\frac{1}{8}$
Scale of Reproduction approx.		1 : 10	1 : 6.3	1 : 3.9

Depth of Field with Rolleinar Lenses

Rolleinar		1		2		f / Stop	
Focused Distance (in inches)		$31\frac{1}{2}$	$23\frac{1}{2}$	$19\frac{3}{4}$	$15\frac{3}{4}$		
Depth of Field (in inches)	from to	$29\frac{1}{2}$ $33\frac{1}{2}$	$22\frac{1}{2}$ $24\frac{3}{4}$	$18\frac{7}{8}$ $20\frac{1}{2}$		5.6	Rolleikin ↓ $2\frac{1}{4} \times 2\frac{1}{4}$ ↓
	from to	$28\frac{3}{4}$ $34\frac{1}{4}$	$22\frac{1}{4}$ $25\frac{1}{4}$	$18\frac{3}{4}$ $20\frac{7}{8}$	$15\frac{1}{8}$ $16\frac{1}{2}$	8	
	from to	28 $35\frac{3}{4}$	$21\frac{5}{8}$ 26	$18\frac{1}{8}$ $21\frac{1}{4}$	15 $16\frac{7}{8}$	11	
	from to	$26\frac{3}{4}$ $38\frac{1}{4}$	$20\frac{7}{8}$ $27\frac{1}{4}$	$17\frac{3}{4}$ 22	$14\frac{5}{8}$ $17\frac{1}{4}$	16	
	from to	$25\frac{1}{4}$ $41\frac{3}{4}$	20 $28\frac{3}{4}$	$16\frac{7}{8}$ $23\frac{1}{4}$	$14\frac{1}{4}$ $18\frac{1}{8}$	22	

Taking-distance measured from lens panel to object. Permissible circle of confusion in this special case (due to the large image and less need for enlarging) = $f/1000$. For increased sharpness further stopping down is required.